

# TYPICAL



## GC6710BD3 SINGLE NEEDLE DIRECT DRIVE LARGE HOOK

SEWING MACHINE WITH THREAD TRIMMER

INSTRUCTION BOOK

### ※NOTE

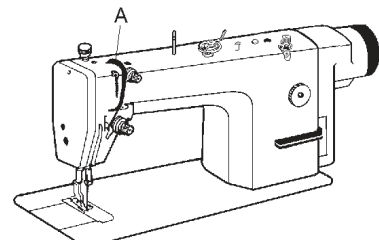

The sewing machine should always first remove the nose upper rubber plug A and the oil supply replenished before it is used for the first time, and also replenished it is used for the first time, and also after long periods of non-use use only the lubricating oil our company, then lift the presser foot and run the machine at a low speed of more than 2000 rpm to check oil distributing condition through oil check window. When lubricating is normal, keep the machine run in at this speed for 30 minutes, then increase the running speed gradually. After one month run-in operation, the machine can be run at the max speed under normal working condition.

### 2. ROTATING HOOK OIL AMOUNT ADJUSTMENT

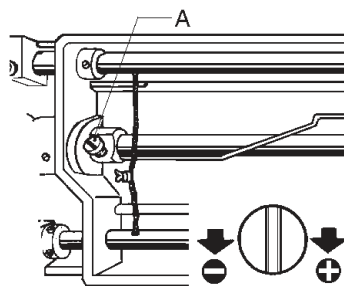

Adjust the oil amount of the rotating hook by turning the oil amount adjusting screw (A). Turn the screw (A) clockwise (in the "+" direction) to increase the oil amount; turn it counter-clockwise (in the "-" direction) to decrease the oil amount.

### 4. NEEDLE INSTALLATION

Turning the balance wheel to lift the needle bar to the upper end of its stroke. Loosen the needle clamp screw while keeping the long groove of the needle leftward, fully insert the needle shank up to the bottom of the needle socket, then tighten the needle clamp screw.  
Note: please take the drive in our motor cover accessory bag to operate.

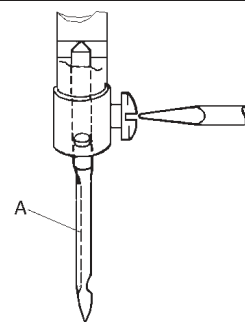

### 5. CONNECTION OF THE CLUTCH LEVER WITH THE PEDAL

(1) Install speed governor A, link speed governor A and pedal B with tie bar, keep tie bar C vertical.  
(2) The optimum tilt angle of pedal is approximately 15 deg.

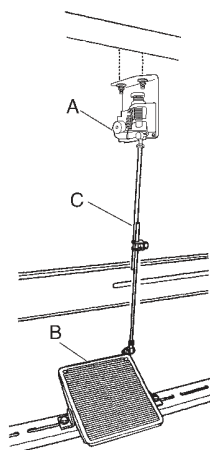

### 6. ADJUST THE OPENING TIME OF THE TENSION DISCS

Within the presser foot lift range, the opening time of the tension discs can be adjusted as follows:

(1) Remove the rubber plug from the back of the arm and Loosen the screw (A) of the knee lift level (left)  
(2) Move the tension releasing cam (D) leftward for earlier opening or rightward for later opening. It will facilitate the adjustment if putting a lifting high block under the presser foot lift.

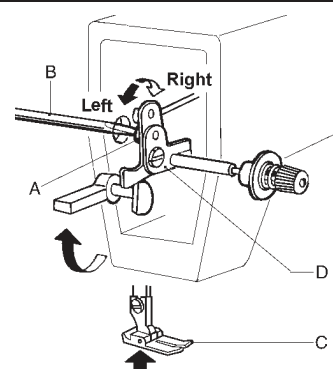

### 7. THREADING

To thread the needle thread, raise the needle bar to the upper end of its stroke, lead the thread from the spool and perform Threading as shown in . To draw the bobbin thread, hold the end of the needle thread and turn the balance wheel to lower the needle bar and then lift it to its highest position. Pull the ends of needle thread and bobbin thread forward under presser foot.

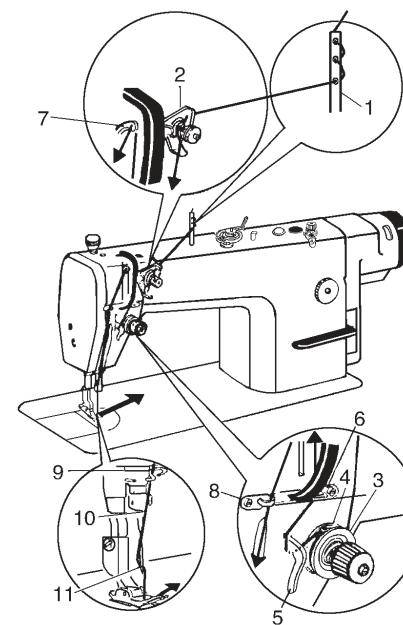

### 8. WINDING THE LOWER THREAD

Turn on the power switch. Place the bobbin (A) onto the bobbin winder shaft (B). Wind the thread several times around the bobbin (A) in the direction indicated by the arrow. Push the bobbin presser arm (C) toward the bobbin (A). Raise the presser foot with the lifting lever. Depress the treadle. Lower thread winding will then start. Once winding of the lower thread is completed, the bobbin presser arm (C) will return automatically. After the thread has been wound on, remove the bobbin and cut the thread with the knife (D).

NOTE:

1. Loosen the screw (E) and move the bobbin presser (C) to adjust the amount of thread wound onto the bobbin.
2. The amount of thread wound onto the bobbin should be a maximum of 80% of the bobbin capacity.

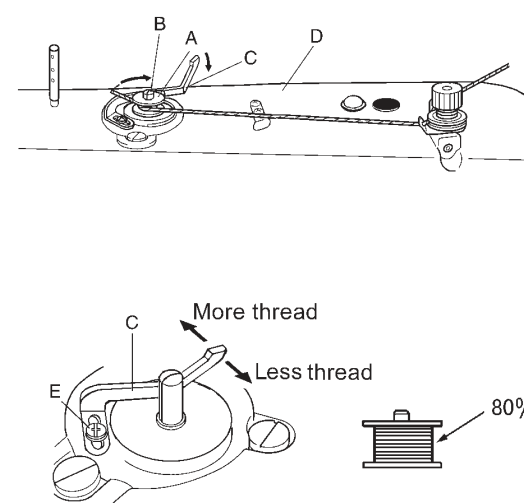

### 9. ADJUST THE PRESSURE OF PRESSER FOOT

Pressure of the presser foot is adjusted in accordance with thickness of materials to be sewn.

First loosen the lock nut (A), for heavy materials, turn the pressure regulating thumb screw as shown in Fig.(a) to increase the pressure, while for light materials, turn the pressure regulating thumb screw as shown in Fig.(b) to decrease the pressure, then tighten the lock nut (A).  
The pressure of the presser foot is recommended to be less as long as normal feeding is ensured.

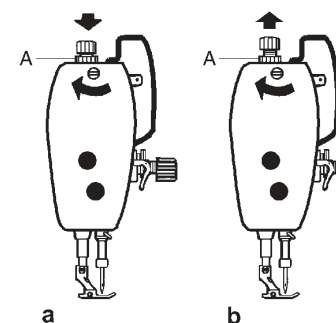

### 10. THREAD TENSION ADJUSTMENT

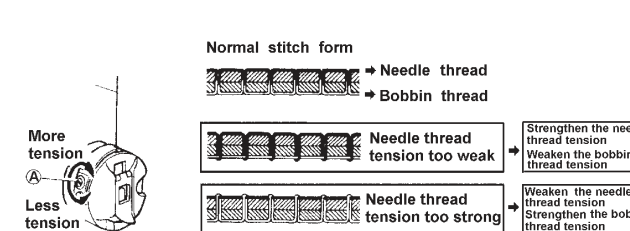

Thread tension should be determined in accordance with the stitch obtained by adjusting the tension of the bobbin thread and needle thread.

The tension of the bobbin thread: to be adjusted by turning the tension spring regulating screw of the bobbin case. After adjusting, insert the bobbin into the bobbin case and hold the end of the thread from the bobbin case to hang the bobbin case. If the bobbin case falls slowly and evenly, the proper tension of the bobbin thread is obtained.

The tension of needle thread: to be adjusted by turning the thumb nut.

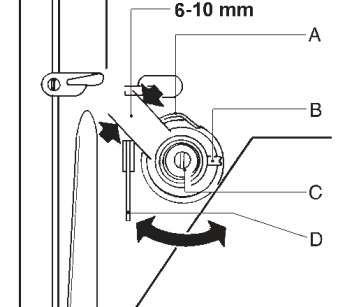
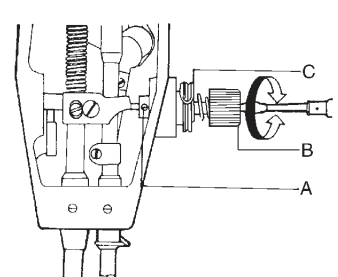

The stroke of the thread take-up spring runs from 6mm to 10mm, when sewing very thin fabrics, reduce the thread take-up spring tension and increase the thread take-up spring stroke, where as increase the thread take-up spring tension and reduce the thread take-up stroke when sewing very thick fabrics.

Adjusting the thread take-up spring tension: First loosen the set screw (A), Turn the tension stud (B) counter-clockwise to decrease the tension of the thread take-up spring (C) to zero. Then turn the tension stud (B) clockwise till the spring (C) comes to the notch of the tension regulating bushing, and again turn the tension stud (B) halfway back (counter clockwise). After the adjustment, tighten the set screw (A).

Adjusting the thread take-up spring stroke: loosen the set screw (B) turn the stud (C) clockwise to increase the stroke or turn stud (C) counter-clockwise to decrease the stroke after the adjustment. tighten the set screw (B).

### 11. ADJUST THE SYNCHRONIZATION OF THE NEEDLE WITH ROTATING HOOK

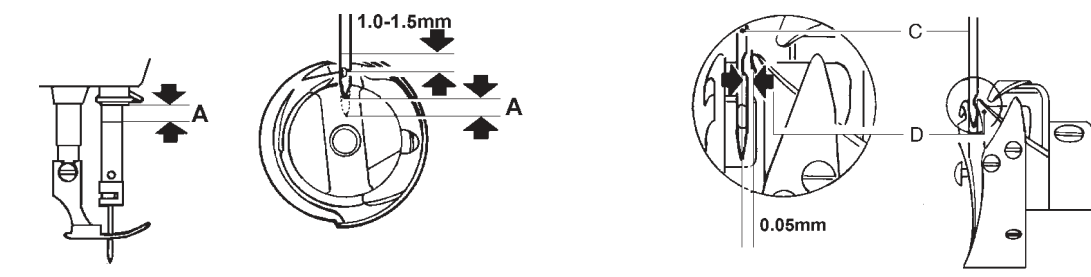

When lifting the needle bar from its lowest position of the stroke to 1.8, the hook point D of the bobbin should align with the center line of the needle and be 1.0-1.5 mm above upper end of the needle eye (Fig.15)

The clearance between the bottom of the needle notch and the hook tip should be 0.05 mm.

### 12. ADJUSTMENT OF STITCH LENGTH AND REVERSE FEEDING

The stitch length can be adjusted by turning the dial knob (A). The figures on the face (B) of the dial show the stitch length in mm. The reverse feed level must be depressed by another hand while adjusting the stitch length (B). The reverse feeding start when the reverse feed lever (B) is depressed, the machine will feed forward again if the reverse feed level is released.

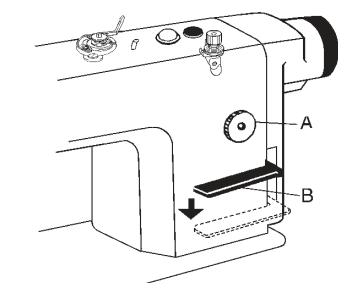

### 13. ADJUSTING THE POSITION OF FEED DOG AND NEEDLE

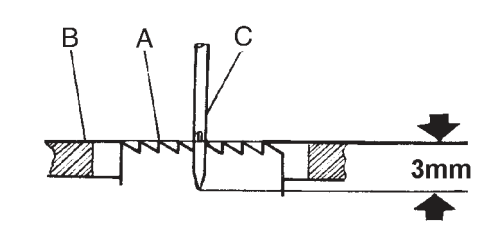

Turn the balance wheel, and lower Feed Dog (A). When the top of the feed dog is flush with needle Plate Surface (B), Needle Point (C) should be 3mm below the needle plate surface.

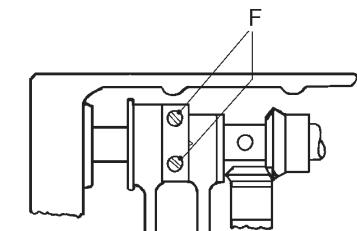

Loosen eccentric wheel screw, turn eccentric wheel and balance wheel separately to adjust the position of needle and feed dog. Then tighten the screw.

### 14. STITCH LENGTH ERROR ADJUSTMENT

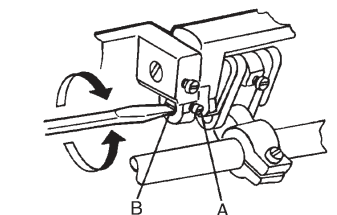

Loosen screw (A) to adjust the stitch length adjusting cam (B). Turn it rightward to narrow the stitch length as forward sewing, and widen it as reverse sewing; turn it leftward to widen the stitch length as forward sewing, and narrow it as reverse sewing.

### 15. FEED DOG HORI ONTALTY ADJUSTMENT

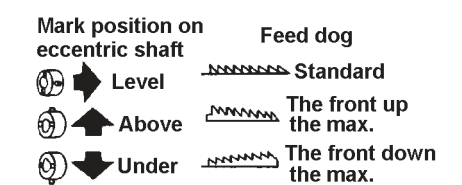

Heighten the front of feed dog to prevent fabric from wrinkling, lower the front of feed dog to prevent fabric from deflection, breaking of hook thread.

### 16. POSITION OF THE FIXED KNIFE AND LEFT KNIFE POINT

(1) The standard position is shown in the figure.  
(2) If the size is larger than the standard, the knife will cut the 3 threads in the meantime or draw the thread out of the needle eye; if smaller, will cause cutting damage, so make sure to avoid that.

(3) As things mentioned above occur, adjustment is done by setting the fixed knife support or the fixed knife (B).

A-the blade B-Fixed knife C-the knife (left)

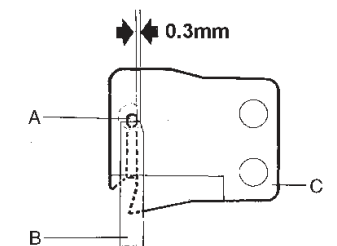

### 17. POSITION OF THE CUTTER DRIVING SHAFT

(1) The Standard position is shown in the figure.  
(2) When assemble it, Cutter Driving Shaft (G) should be first put in Cutter Driving Crank (A).  
(3) Set Thread Cutting Cam Crank (D) on the cutter driving shaft with reference to the standard position.  
(4) Set Stopper (F), make sure that there is no clearance between parts around the cutter driving shaft, and rotate steadily.

A-knife driving crank  
B-spring end cover  
C-spring  
D-thread cutting cam crank  
E-thread cutting cam crank 2  
F-stopper  
G-knife driving shaft

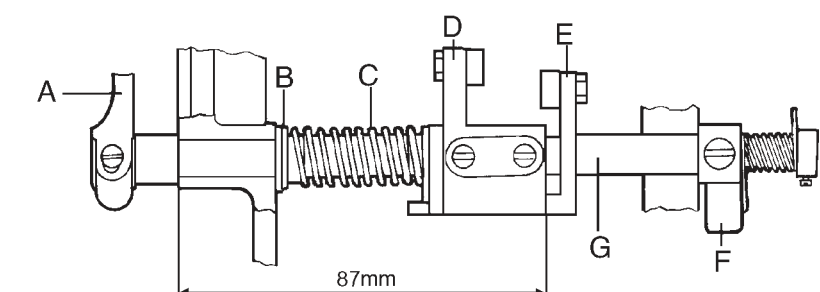

## 18.THE ELECTROMAGNET CORE STROKE

- (1)The standard stroke of the electromagnet core is 6mm.
  - (2)The stroke can be adjusted with Positioning screw (A).
- B--thread cutting electromagnet holder  
C--thread cutting cam crank 2  
D--driving bar  
E--thread cutting electromagnet

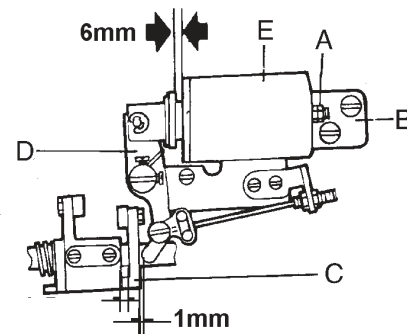

## 19.INSTALLING THREAD CUTTING CAM

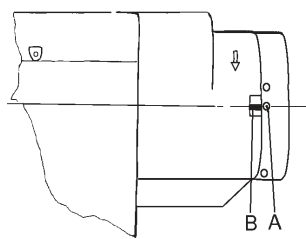

- (1)Align No.2 Positioning Mark (A) on the balance wheel with Positioning Mark (B) on the motor cover.

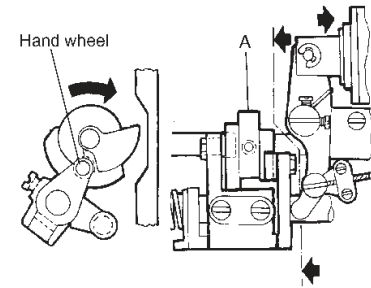

- (2)As the thread cutting electromagnet works, Thread Cutting Cam (A) run in normal rotating direction. Fix the cam when Cam (A) is engaged with Roller (B).

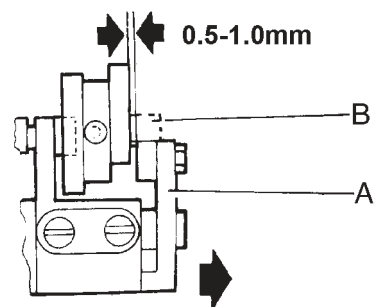

- (3)Stop the operation of the electromagnet, reset Cam Driving Crank (A), Cam (B) is separated from the engagement with the roller,the standard clearance is 0.5-1.0mm.

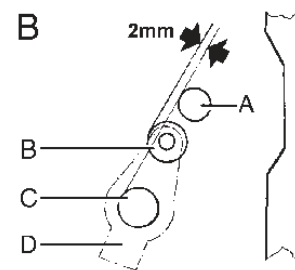

- NOTE:  
1.the figure shows the standard position of Cam Driving Crank (D) before operation.  
A--hook shaft B--roller C--cutter driving shaft

- 2.It may change the positions mentioned above to remove the stopper, then adjust with Screw (A), and readjust the above .

## 20.ADJUSTING KNIFE CUTTING ENGAGEMENT

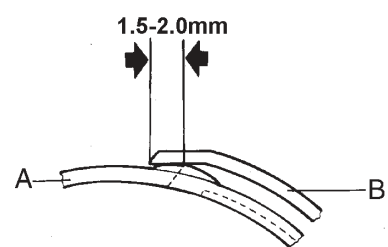

- ①When the electromagnet works, turn the machine, the movable knife (A) follows the motion of the thread cutting cam. The maximum degree of cutting engagement is 1.5-2.0mm (B--the fixed knife)②Adjust the cutter driving crank if necessary.

## 21.ADJUSTING CUTTING PRESSURE

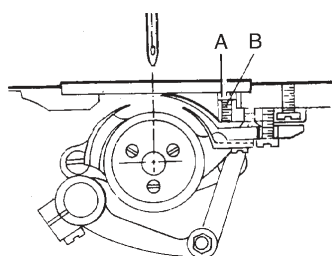

- (1)When cutting thick thread, increase the cutting force.
- (2)For adjusting cutting force, loosen Set Nut (A),and adjust Screw (B).

## 22.ADJUSTING NEEDLE THREAD TENSION

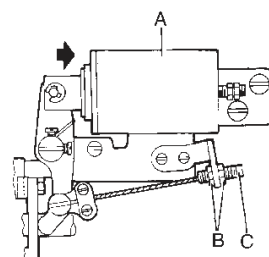

- There should be a clearance of 1mm between the two discs while the thread cutting electromagnet (A) is working.

For adjustment, loosen Nut (B),and move soft thread (C).

Note: If the clearance is too small, the thread end left

- after cutting is too short and may easily go away from the needle eye; otherwise the tension is poor and affect the needle thread tension.

## 23.THREAD END REMAINS ADJUSTMENT

- To get the needle thread end remains properly, adjust Nut (A).
- Turn rightward: get shorter  
Turn leftward: get longer

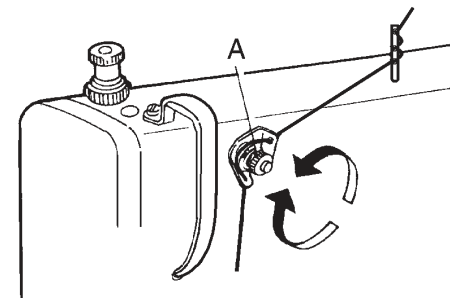

## 24.INSTALLING REVERSE STITCH ELECTROMAGNET

- Adjust the position of Electromagnet (A) properly to guarantee the flexible connection of the magnet with the link lever and the convenient operation of Reverse Stitch Bar (B),then set with a screw.

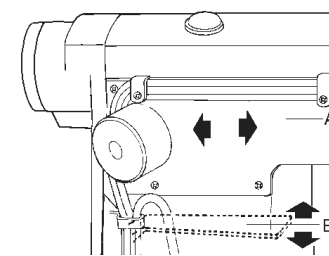

## 25.REVERSE STITCH SWITCH

- The figure shows the normal state.It can perform reverse sewing to switch on.If move the switch to the dotted line shown in the figure,and switch on,the reverse sewing can not be performed.

- For the double switch model:  
push button A, it can perform back tacking sewing push button B it can perform reverse sewing.

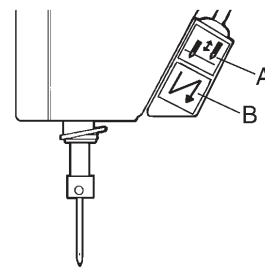

## 26.THREAD RETAINING DEVICE

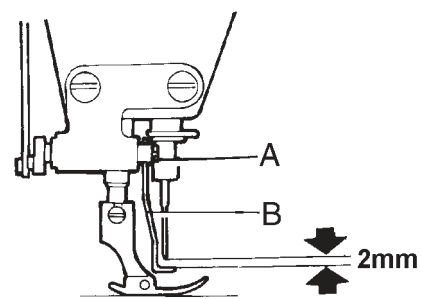

- 1.Thread Retainer Height  
(1) Standard height: 2 mm from the thread retainer as the needle in its highest position.  
(2) To adjust Thread Retainer (B), loosen Screw (A).

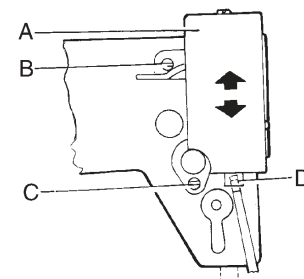

2. Thread Retainer Working position.  
(1) When the magnet move into the electromagnet completely, the standard distance between the thread retainer and the center of the needle should be 0-2 mm.  
(2)To adjust its position, loosen Screw (C), Screw (B), and adjust the position of Electro-magnet Asm(A).  
D--magnet

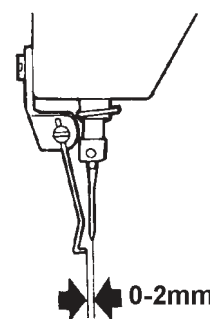

## 27.HOOK. BOBBIN CASE AND BOBBIN

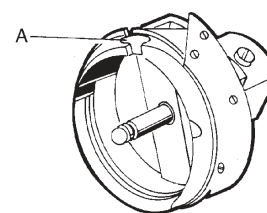

- 1.There is a thread groove (A) in the special hook for thread cutting sewing machine.

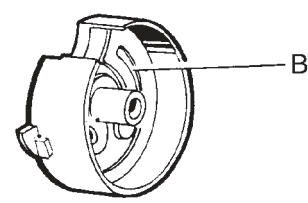

- 2.The bobbin case used in the machine should be with a spring (B) in its bottom, which prevents the bobbin from running without loading.

## 28.PERIODICAL CLEANING

- 1)Cleaning feed dog  
Remove the throat plate and clear off the dust and lint between feed dog tooth slots.
- 2)Cleaning rotating hook  
Swing out the machine head and clean the hook.Wipe the bobbin case with soft cloth.
- 3)Cleaning oil pump screen  
Swing out the machine head and clear off the dust and dirt on oil pump screen.

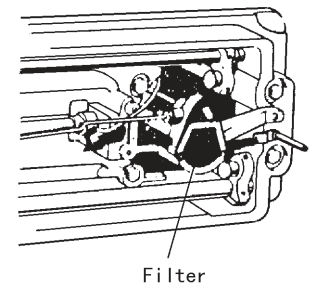
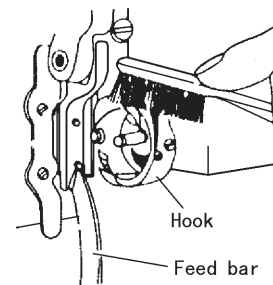
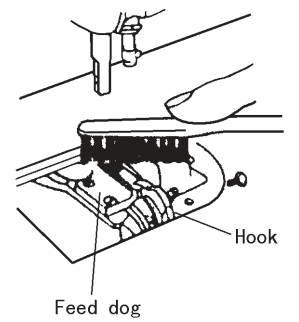

## GC6710BD3 series machine's main technical data

Item	Model	B
Application		Thick materials
Sewing speed		3000 spm
Max. Stitch length		7mm
knee controlled Presser foot lifting height		13mm
Rotating shuttle		Double automatic oiling
Needle		DPx5 #18-#22

When sewing at speeds of 4,000 rpm or higher,set the stitch length to 4mm or less.

## GC6710

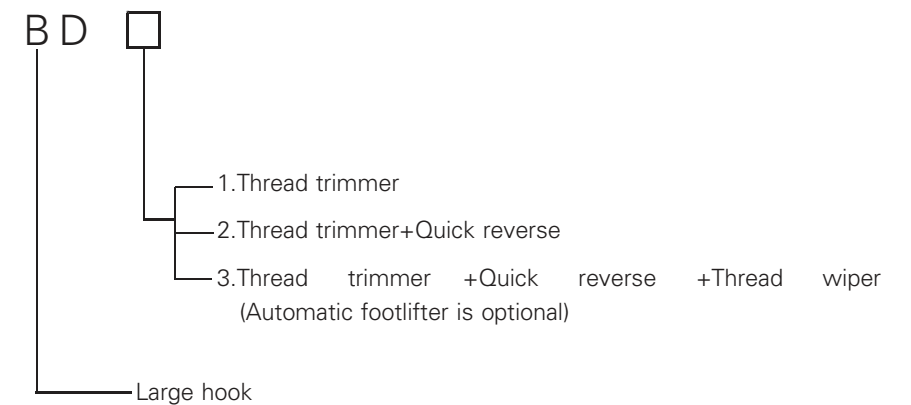

XI'AN TYPICAL INDUSTRIES CO., LTD.

Add: No. 335 Taibai South Road,  
Xi'an, P. R. China - 710068  
Tel : +86 -29 -88279091 88279150

Fax : +86 -29 -88249715 88245215  
E-mail: typical@chinatypical.com  
Http: www.chinatypical.com

# TYPICAL



## GC6710BD3 SINGLE NEEDLE DIRECT DRIVE LARGE HOOK

SEWING MACHINE WITH THREAD TRIMMER

### PARTS CATALOGUE

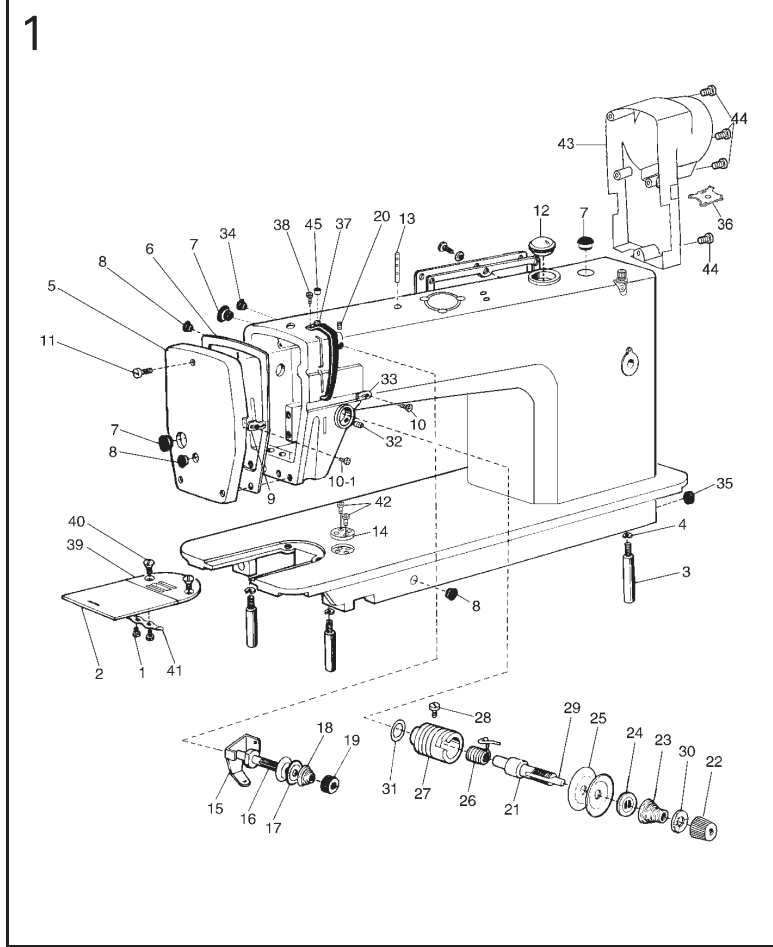

#### 1、ARM AND BED MECHANISM

No.	Ref.No.	Description	Qt.
1	022170003	Screw	2
2	022170001	Slide plate	1
3	048100005	Leg	3
4	S4A0400011	Spring washer	3
5	238100001	Face plate	1
6	S150651047	O-type ring	1
7	022130003	Rubber plug(Φ 19)	3
8	022130004	Rubber plug(Φ 11.8)	3
9	078130001	Thread guide on face plate	1
10	022130006	Screw	1
10-1	B040750494	Screw	1
11	022100004	Screw	1
12	02218	Oil check window	1
13	236000009	Thread guide pole	1
14	057100008	Ruler plate	1
15	036240001	Pretension thread guide	1
16	036240002	Thread tension stud	1
17	022150003	Thread tension disc	2
18	036240003	Tension spring for pretension	1
19	036240004	Thread tension nut	1
20	124100006	Set screw	1
21	022160001	Thread tension stud	1
22	124130001	Thread tension nut	1
23	048110001	Thread tension spring	1
24	022160004	Thread tension releasing disc	1
25	022160005	Thread tension disc	2
26	048110002	Thread take-up spring	1
27	022160007	Thread tension regulator bushing	1
28	022160008	Screw	1
29	238100004	Thread tension releasing pin	1
30	022160010	Stop disc	1
31	022160011	O-type ring	1
32	022100013	Set screw	1
33	078100005	Thread guide	1
34	022100015	Rubber plug(Φ 8.8)	2
35	022100016	Rubber plug(Φ 27)	1
36	236170002	All purpose screwdriver	1
37	078200002	Thread take-up lever guard	1
38	022200004	Screw	1
39	048100006	Needle plate(B2.6)	1
40	022100020	Screw	2
41	022170002	Slide plate spring	2
42	124100004	Screw	1
43	238100003	Motor cover	2
44	S150237005	Screw M5x25	1
45	022100017-V	Rubber plug 5.7	1

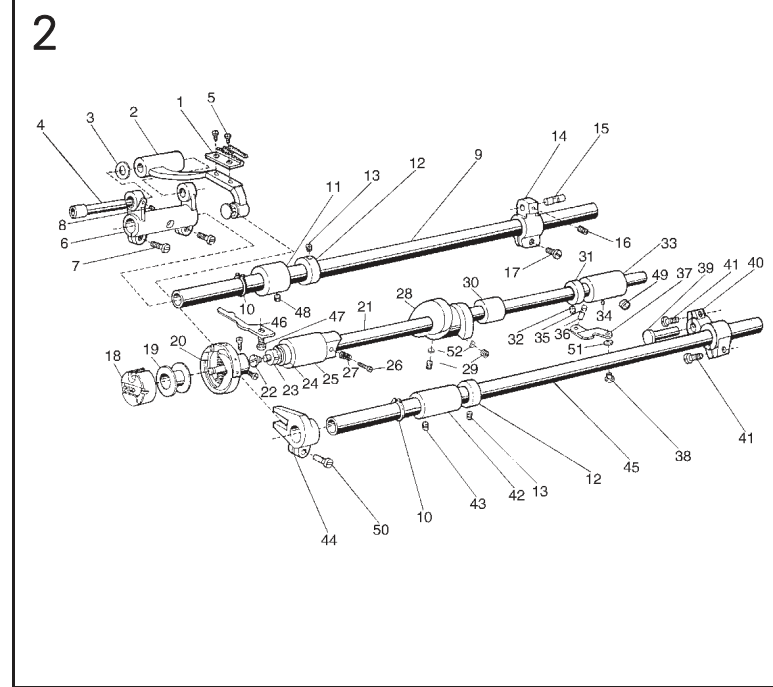

#### 2、FEEDING AND FEED LIFTING AND ROTATING HOOK MECHANISM

No.	Ref.No.	Description	Qt.
1	022610003	Feed dog	1
	165400102	Feed dog	1
2	036411	Feed bar	1
3	022610006	Washer	1
4	036410002	Shaft for feed bar	1
5	022610004	Screw	2
6	022611000	Feed rock shaft crank	1
7	022612000	Screw	2
8	022200019	Screw	1
9	124600002	Feed rock shaft	1
10	S4A0500010	C-type stop ring 15	2
11	022600004	Bushing for feed rock shaft	1
12	022620001	Collar for feed rock shaft	2
13	022320002	Screw	4
14	114400001	Feed rock shaft crank(right)	1
15	036400204	Pin	1
16	036550005	Screw	1
17	022640003	Screw	1
18	12042	Bobbin case complete	1
19	078400005	Bobbin	1
20	12041	Rotating hook complete	1
21	120400001	Hook shaft	1
22	022411001	Filter screw	1
23	022411002	Filter	1
24	03647	Oil seal	1
25	036400010	Hook shaft bushing(left)	1
26	022400005	Oil adjusting screw	1
27	022400006	Coil spring	1
28	036450001	Thread cutting cam	1
29	B096339088	Screw	2
30	036400012	Hook shaft bushing(middle)	1
31	022420001	Collar for hook shaft	1
32	022200009	Screw	1
33	036460001	Hook shaft bushing(right)	1
34	022430002	Oil pipe for hook shaft bushing	1
35	036400015	Plunger	1
36	036400016	Plunger spring	1
37	078400006	Guide plate	1
38	022510004	Screw	1
39	022600007	Hinge pin	1
40	036400017	Feed lifting rock shaft crank(R)	1
41	022600016	Screw	2
42	022600012	Bushing for feed lifting shaft(L)	1
43	022200002	Screw	1
44	036484001	Feed lifting fork	1
45	124600003	Feed lifting rock shaft	1
46	078400003	Hook positioner	1
47	022400015	Screw	1
48	022200009	Screw	1
49	022200002	Screw	1
50	022640003	Screw	1
51	S4A0400011	Washer	1
52	165400001	Washer	2

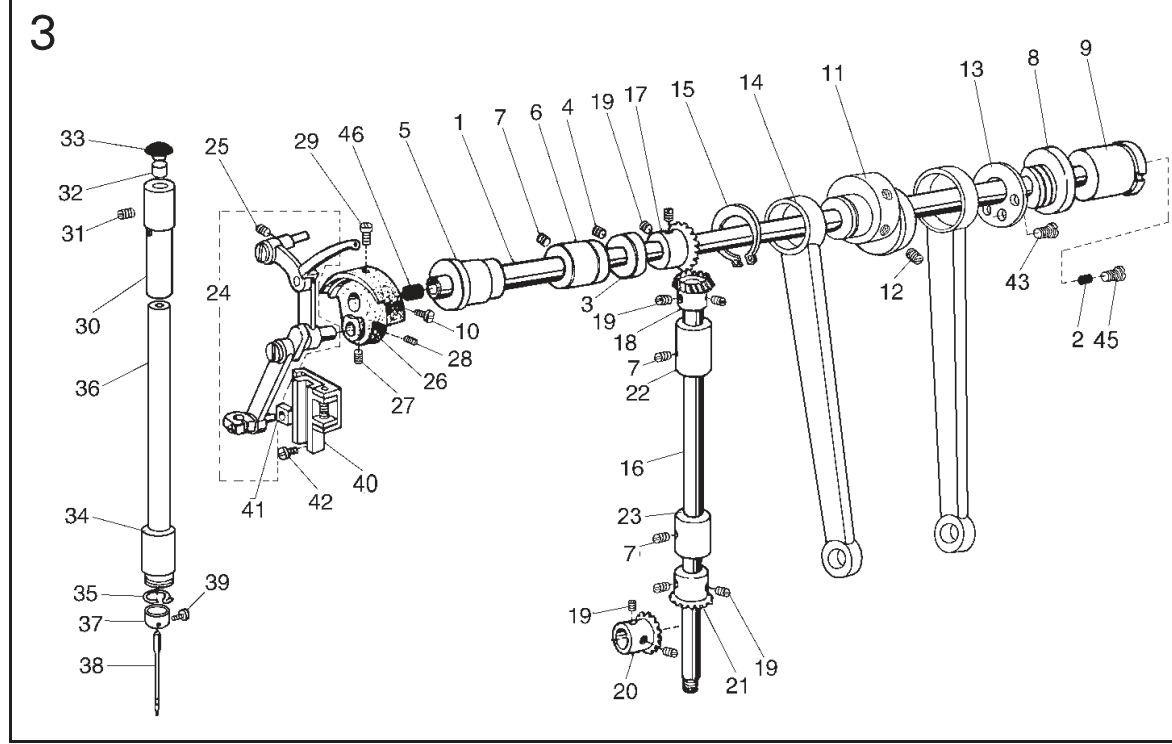

#### 3、ARM SHAFT AND VERTICAL SHAFT THREAD TAKE-UP MECHANISM

No.	Ref.No.	Description	Qt.
	078300002	Vertical shaft bushing(lower)	1
	269C22000	Needle bar link thread take up lever asm	1
1	238200001	Arm shaft	1
2	022320001	Collar for arm shaft	1
3	022320002	Screw	2
4	022320003	Arm shaft bushing(left)	1
5	022320004	Arm shaft bushing(middle)	1
6	022200002	Screw	3
7	238200003	Coupling	1
8	238200004	oil seal	1
9	BX85874009	Screw	1
10	114300001	Eccentric wheel	1
11	022200002	Eccentric wheel screw	2
12	036300004	Spacer	1
13	022343	Crank rod for lifting rock shaft	1
14	022342001	Spacer	1
15	022350001	Vertical shaft	1
16	ZOA180891	Bevel gear for arm shaft	1
17	ZOA180892	Bevel gear for vertical shaft(upper)	1
18	022220003	Set screw	8
19	ZOA180886	Bevel gear for hook shaft	1
20	ZOA180885	Bevel gear for vertical shaft(lower)	1
21	022300011	Vertical shaft bushing(upper)	1
22	078300002	Vertical shaft bushing(lower)	1
23	269C22000	Needle bar link thread take up lever asm	1
24	022200002	Screw	2
25	048220001	Needle bar crank	1
26	BXB7459009	Screw	7
27	BX85876009	Bearing	1
28	022200007	Set screw	1
29	153200004	Needle bar bushing(upper)	1
30	022200010	Felt plug	1
31	022200011	Rubber plug	1
32	124200006	Needle bushing(lower)	1
33	022230002	Thread guide	1
34	078200004	Needle bar	1
35	DP x 5 22#	Needle	1
36	048200004	Thread guide for needle bar	1
37	022200017	Screw	1
38	269C21000	Slide block	1
39	269C21001	Slide block	1
40	022200019	Set screw	2
41	162330001	Screw	3
42	022310002	Rubber plug	1
43	207302001	Friction wheel(Φ 7.4x10)	1
44	S150224011	Screw	2

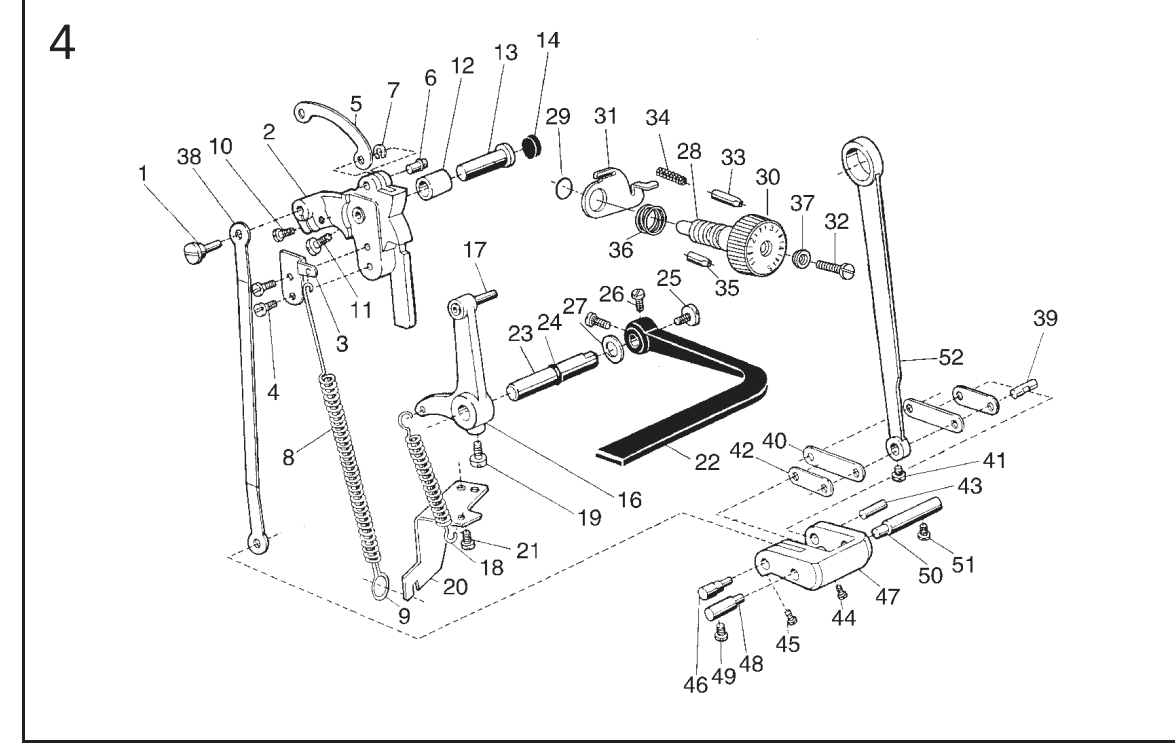
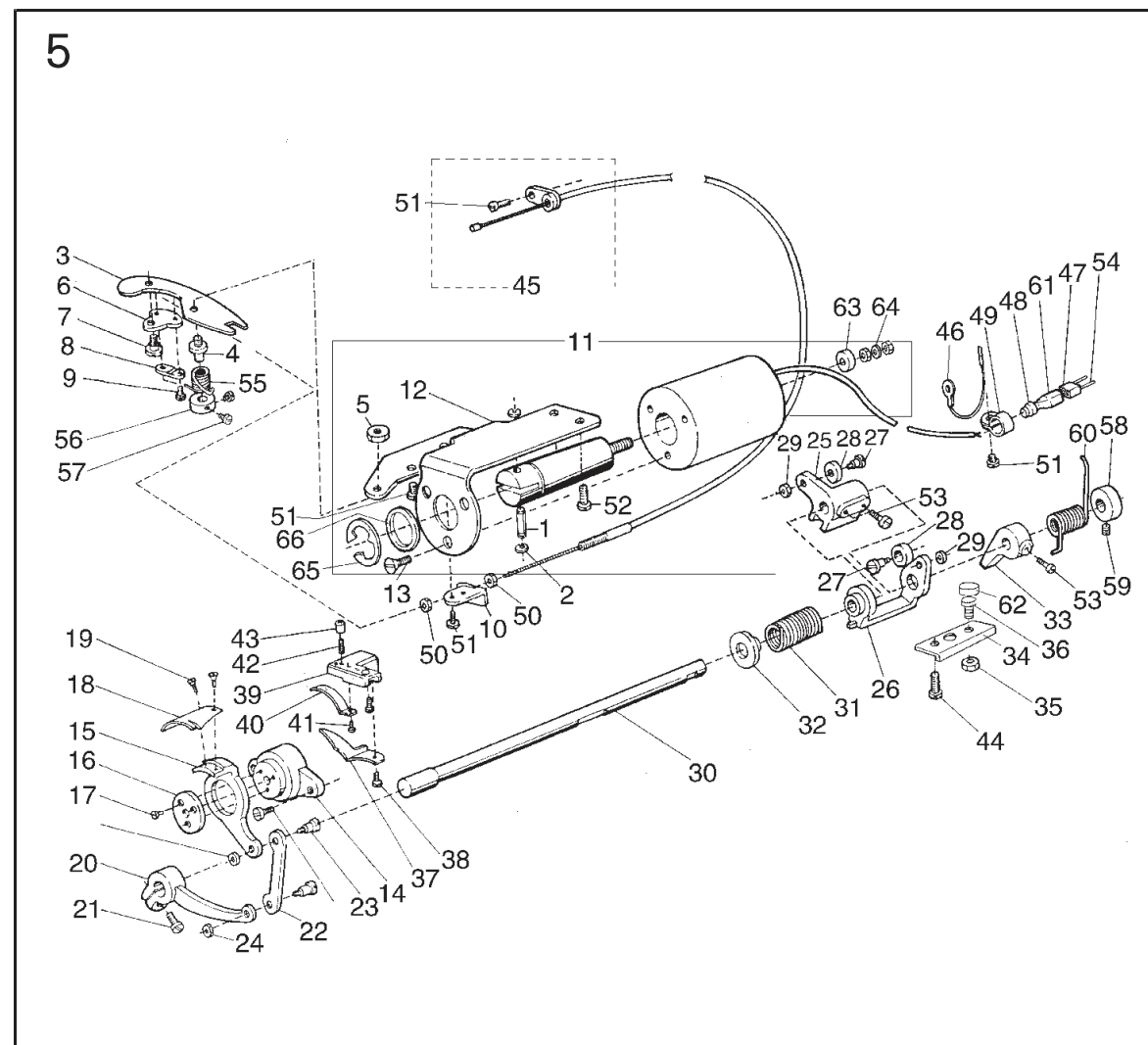

#### 4、STITCH LENGTH REGULATING MECHANISM

No.	Ref.No.	Description	Qt.
	022500011	Washer	1
	124510002	Screw bar	1
	124510003	O-type rubber ring	1
1	036500001	Set pin	1
2	114500001	Feed regulator	1
3	036510002	Spring retainer	1
4	022200019	Screw	2
5	036510003	Link	1
6	036510004	Pin	1
7	S4B1202008	Split retaining ring	1
8	036510005	Coil spring	1
9	036510006	Spring holder	1
10	022640003	Screw	1
11	022540004	Screw	1
12	238300001	Bushing for feed regulator	1
13	022500004	Pin shaft	1
14	238300002	Rubber plug	1
16	036520001	Reverse sewing crank	1
17	036520002	Reverse sewing crank shaft	1
18	036520003	Coil spring	1
19	022500013	Screw	1
20	036500005	Spring holder	1
21	022510004	Screw	1
22	124500004	Reverse sewing lever	1
23	0365310001	Shaft for reverse sewing lever	1
24	S4A0604005	O-type ring 6.3 x 1.8G	1
25	022540003	Screw	1
26	022540004	Screw	2
27	022500011	Washer	1
28	124510002	Screw bar	1
29	124510003	O-type rubber ring	1
30	236A00002	Dial	1
31	236000006	Lock	1
32	238300004	Screw	1
33	236000008	Pin (longer)	1
34	022500009	Spring	1
35	217N00025	Pin (shorter)	1
36	236000007	Spring	1
37	036540004	Bushing	1
38	036550003	Stitch length regulating link	1
39	036570002	Crank link pin	1
40	114500003	Link(long)	2
41	036550005	Screw	1
42	036558001	Link(short)	2
43	036550007	Pin(short)	1
44	036550006	Screw	1
45	036550008	Screw	1
46	036550009	Eccentric shaft	1
47	036550010	Stitch length adjusting crank	1
48	036580002	Set pin (left)	1
49	022640003	Screw	1
50	036580001	Set pin (right)	1
51	022640003	Screw	1
52	036550002	Feed link	1

#### 5、KNIFE ACTUATING MECHANISM

No.	Ref.No.	Description	Qt.
	165720001	Stopper plate	1
	S120501011	Nut M6	1
1	036800009	Pin	1
2	S4B1202008	Split retaining ring	2
3	036710001	Flexible driving lever	1
4	036710002	Screw	1
5	022910010	Nut	1
6	036710003	Bracket for flexible bracket	1
7	036710004	Screw	1
8	036710005	Flexible wire connecting bracket	1
9	036710006	Screw	2
10	036710007	Holder for flexible wire	1
11	036711000	Solenoid assy for thread trimmer	1
12	036712	Solenoid mounting bracket	1
13	S150218005	Screw	3
14	036721001	Knife holding saddle	1
15	036721002	knife base(left)	1
16	036721003	Washer	1
17	036721004	Screw	3
18	036720002	Blade(left)	1
19	036720003	Set screw	2
20	036720004	Knife driving crank	1
22	036720005	Link	1
23	036720006	Screw	2
24	036720007	Nut	2
25	036730001	Cam follower crank(1)	1
26	036730002	Cam follower crank(2)	1
27	036730003	Roller stud	2
28	036730004	Roller stud	2
29	036730005	Nut	2
30	036700004	Knife driving shaft	1
31	036700005	Coil spring	1
32	120700002	Bushing	1
33	165720004	Stopper	1
34	165720001	Stopper plate	1
35	S120501011	Nut M6	1
36	165720002	Screw	1
37	036750001	Thread guide	1
38	120720001	Thread guide	1
39	036750002	Bracket for fixed blade	1
40	120720002	Fixed knife	1
41	036750004	Set screw	1
42	036750005	Adjusting screw	1
43	036750006	Adjusting nut	1
44	036800002	Set screw	2
45	03676	Flexible wire asm	1
46	036770000	Earth wire asm	1
47	108500003	Plug	1
48	036700013	Rubber sleeve	1
49	036700014	Wire clamp	1
50	S120501005	Nut M5	2
51	022200019	Screw 4.37 x 40/8	8
52	036800002	Screw	2
53	165730008	Screw	3
54	036911002	Pin	2
55	036710009	Coil spring	1
56	036710010	Collar for driving lever	1
57	036550008	Screw	2
58	036780001	Collar for knife driving shaft	1
59	022320002	Screw	1
60	036700016	Coil spring	1
61	165P11104	Guard for plug	1
62	165720003	Rubber washer	1
63	165710001	Rubber washer	1
64	S150632004	Washer	1
65	S150651005	Split retaining ring	1
66	036711001	Washer	1

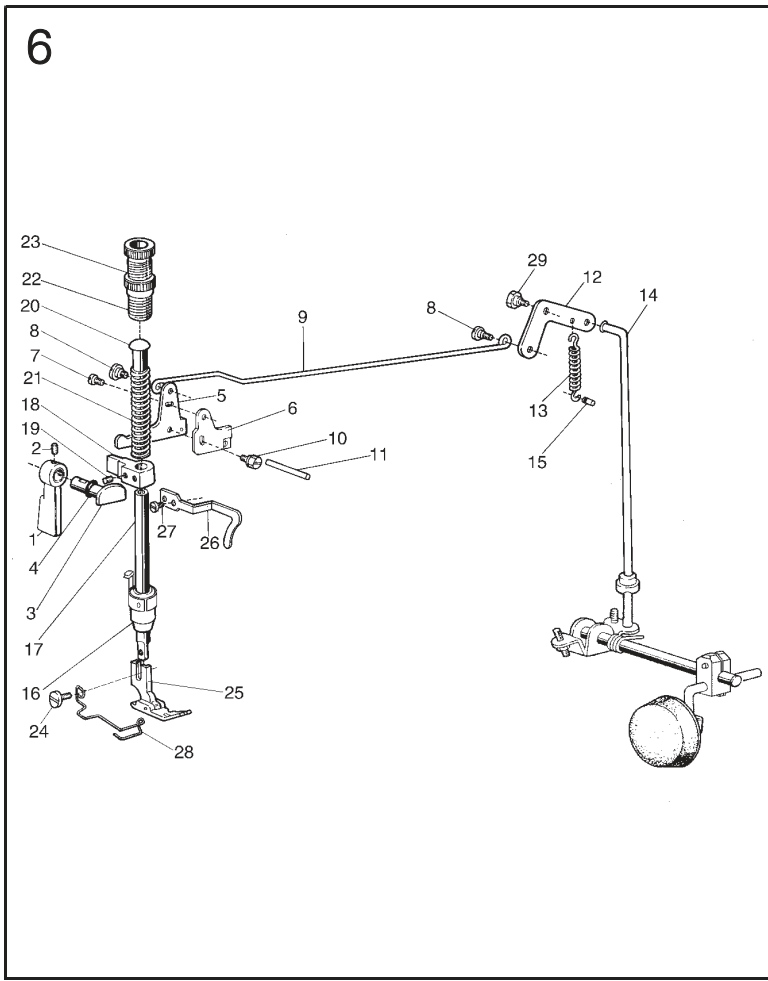

6、PRESSER FOOT MECHANISM

No.	Ref.No.	Description	Qt.
1	036600011	Presser bar lifter	1
2	022200009	Screw	1
3	036620001	Presser bar lifting cam	1
4	036620002	Oil seal(4.5 x 1.8G )	1
5	036631001	Knee lifter lever (left)	1
6	022722001	Tension relasing cam	1
7	022723000	Screw	1
8	022720002	Screw	2
9	238400002	Knee lifter rod	1
10	022700005	Screw	1
11	238400003	Thread releasing pin	1
12	022730001	Knee lifter lever (right)	1
13	022730002	Coil spring	1
14	022730003	Knee lifter connecting rod	1
15	022700008	Pin for spring	1
16	022700009	Bushing for presser bar	1
17	022700010	Presser bar	1
18	238400001	Presser bar guide bracket	1
19	022100013	Screw	1
20	022700012	Presser bar spring guide	1
21	048700002	Presser bar spring	1
22	022750001	Thumb screw	1
23	022750002	Lock nut	1
24	022700015	Screw	1
25	04871	Presser foot asm	1
26	027701100	Presser foot asm	1
27	238400004	Thread guide	1
28	022200004	Screw	1
29	057700002	Presser foot spring	1
30	022730004	Screw	1

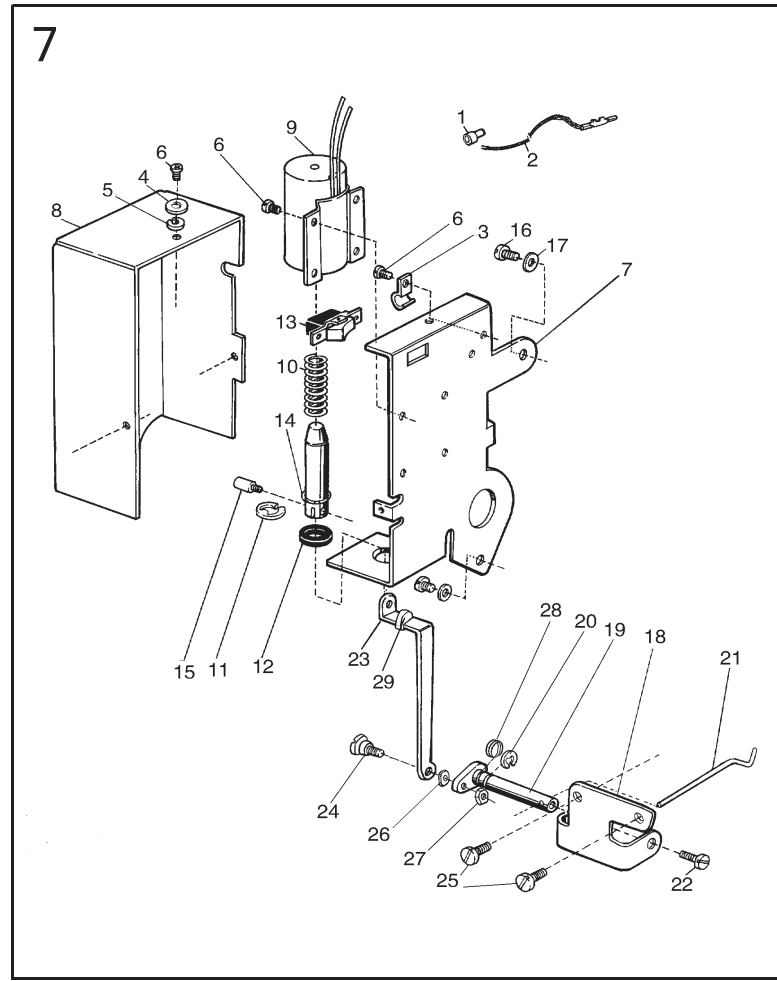

7、WIPER MECHANISM

No.	Ref.No.	Description	Qt.
1	036910001	Wire connector	1
2	036911001	Wire	1
3	036910003	Cord clamp	1
4	S4A0400012	Washer3	8
5	S8A3103002	Washer3	8
6	S8A3101005	Screw M3 x 6	8
7	036910004	Solenoid bracket	1
8	036910005	Cover for wiper mech	1
9	036910006	Solenoid for wiper	1
10	036910007	Coil spring	1
11	S150651002	Retaining ring9	1
12	036910008	Rubber ring	1
13	036910009	Switch for wiper	1
14	036910010	Washer	1
15	036900002	Screw	1
16	022510004	Screw	2
17	036900003	Washer	2
18	036920001	Wiper bracket	1
19	238500001	Wiper shaft asm	1
20	S4B1202008	Retaining ring 4	2
21	036920003	Wiper	1
22	022610004	Screw	1
23	036920004	Link	1
24	036921007	Shaft	1
25	036900005	Screw	2
26	036921006	Washer	1
27	S120501001	Nut M3	1
28	238500002	Washer	1
29	165900001	Rubber washer	1

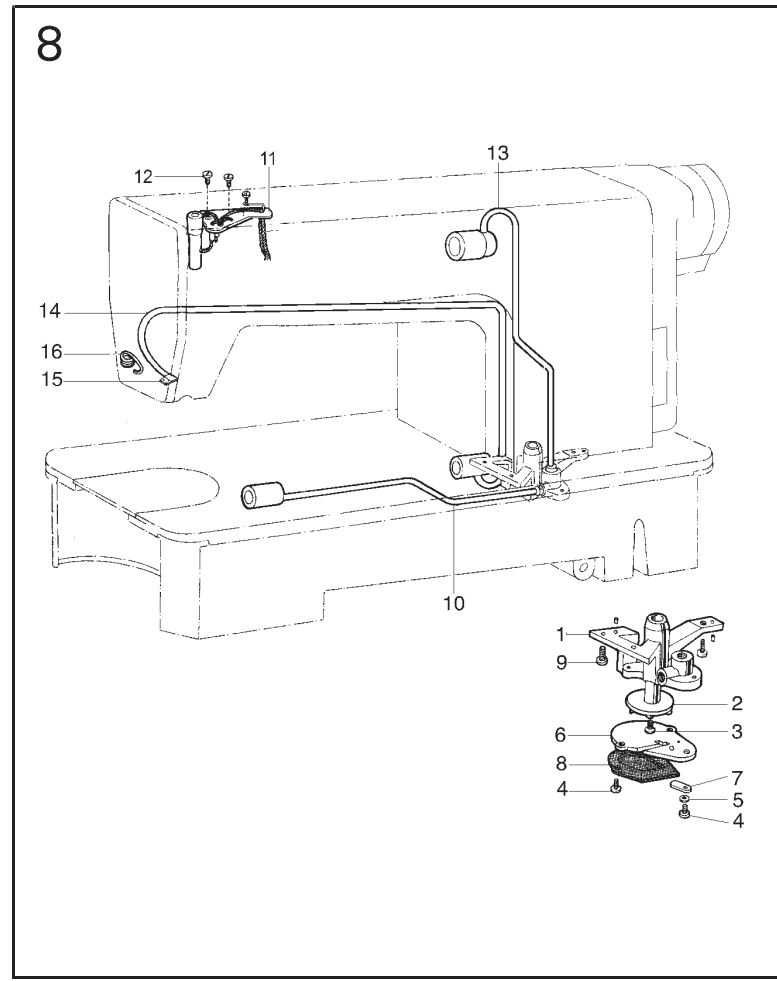

8、OIL PUMP MECHANISM

No.	Ref.No.	Description	Qt.
1	022800001	Oil pump	1
2	022800002	Oil pump impeller	1
3	022800003	Screw	1
4	022800004	Screw	3
5	S4A0400012	Springee washer3	1
6	078800001	Oil pump fitting plate	1
7	022800007	Oil adjusting plate	1
8	02281	Oil pump screen asm	1
9	022800009	Screw	3
10	036101000	Oil pump for hook shaft	1
11	269C60000	Oil braid fitting plate	1
12	036550005	Screw	2
13	02284	Oil pump for arm shaft	1
14	078800002	Oil return pipe	1
15	238610001	Felt pouch for return oil filter	1
16	036100002	Oil filter holder	1

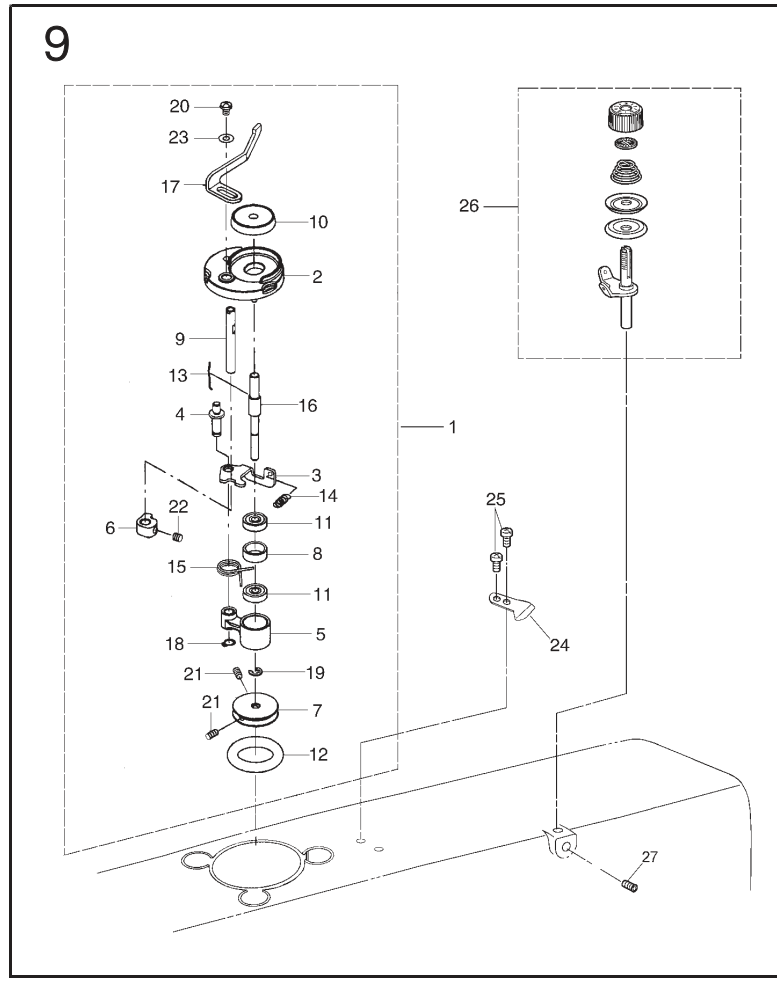

9、BOBBIN WINDER MECHANISM

No.	Ref.No.	Description	Qt.
1	207107000	Bobbin winder complete	1
2	207107004	Bobbin winder support	1
3	207107014	Bobbin winder lever	1
4	207107012	Bobbin winder lever shaft	1
5	207107006	Bobbin winder crank	1
6	207107011	Bobbin winder cam	1
7	207107008	Bobbin winder wheel	1
8	207107007	Bear bushing	1
9	207107010	Bobbin winder cam shaft	1
10	207107003	Bobbin support	1
11	S150866067	Bear 625ZZHR	1
12	207107009	Rubber ring	1
13	207107002	Spring	1
14	207107005	Spring	1
15	207107013	Spring	1
16	207107001	Bobbin winder shaft	1
17	207107015	Wrench	1
18	W120607001	Retaining ting C6	1
19	B062060768	Retaining ting E4	1
20	S150237046	Screw M4X5	1
21	S150633007	Waher plain	1
22	S150224008	Screw M5X5	1
23	B084060874	Screw M4X6	1
24	001100009	Knife	1
25	022830004	Screw SM3.57	2
26	BXF9116009	Thread tension complete(Small)	1
27	022200009	Screw	1

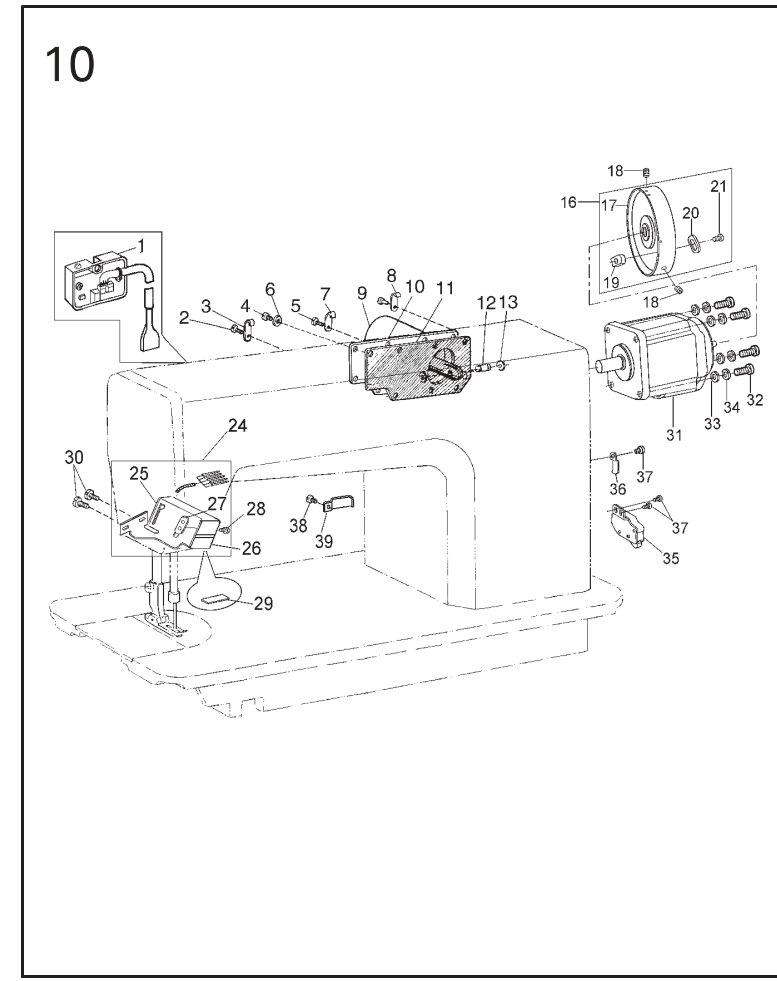

10、REVERSE SEWING AND DETECTOR MECHANISM

No.	Ref.No.	Description	Qt.
1	238A10001	Detector componts	1
2	022200019	Screw	2
3	236000010	Wire clamp	1
4	022640003	Screw (shorter)	6
5	022100006	Screw (longer)	2
6	022100007	Washer	8
7	236000011	Wire clamp	1
8	027A00010	Wire clamp	1
9	238731000	Electric-magnet for reverse sewing	1
10	165820001	Side cover	1
11	036850001	Wahser	1
12	036800009	Pin	1
13	S4B1202008	Split retaining ring	2
16	238710000	Hand wheel asm	1
17	238710001	Hand wheel	1
18	B098049074	Screw M6x10	2
19	238710002	Magnet block asm.	1
20	230100013	Washer	1
21	B040600294	Screw M4x8	1
24	238750000	Reserve sewing switch asm	1
25	236190001	Bracket of reserve sewing switch	1
26	230123004	Shell of reserve sewing switch	1
27	230123002	Spacer of reserve sewing switch	1
28	B048600494	Screw M4x6	1
29	230123005	Cover of reserve switch	1
30	022200019	Screw	2
31	238700002	Motor	1
32	B048509294	Screw M5x18	4
33	B084050974	Flat Washer S5	4
34	B082050864	Spring Washer	4
35	238720000	Safety switch asm	1
36	BXF9716909	Clamp	1
37	B048500294	Screw M5x8	3

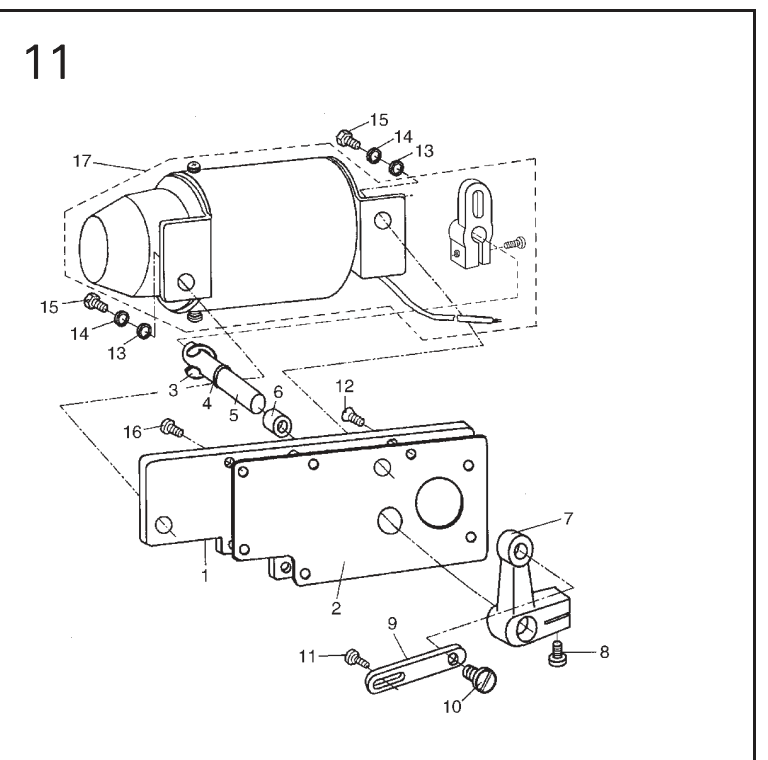

11.AUTOMATIC FOOT LIFTER MECHANISM

No.	Ref.No.	Description	Qt.
1	108C01000	Back plate	1
2	036850001	Gasket for back plate	1
3	S150651004	Stop ring 8	1
4	S150633003	Washer 10	1
5	108C02004	Shsft	1
6	110280000	Seal	1
7	108C02002	Link crank	1
8	022612001	Screw SM3/16" ( 4.76 ) x28/12	1
9	108C02001	Link	1
10	108C02003	Screw	1
11	108C00001	Hinge screw	1
12	108C01003	Screw SM11/64" ( 4.37 ) x40/9.4	1
13	S150632002	Washer 6	2
14	S150632003	Washer 6	2
15	S150258010	Screw M6x10	2
16	022640003	Screw SM11/64 " ( 4.37 ) x40/12	7
17	108C03000	Foot lifter solenoid	1

12、OIL RESERVOIR AND ACCESSORIES

No.	Ref.No.	Description	Qt.
1	036C10001	Oil reservoir asm	1
2	022910002	Screw	1
3	022910003	Washer	1
4	022910005	Oil gasket	1
5	165F01001	Knee lifter lifting pin	1
8	006F00030	Thread spool asm	1
9	02299	Hinge with rubber cushion	2
10	022900009	Cushion(B)	2
11	022900010	Cushion(S)	2
12	W050202001	Oil pot	1
13	022900012	Magnet block	1
14	W050102068	Screw drive(long)	1
15	W050102034	Allen wrench 2	1
	W050102035	Allen wrench 3	1
16	W210105011	Double open-end wrench	1
17	022900017	Oil tank	1
18	W060302076	Machine head cover	1
19	022900024	Needle bag	1

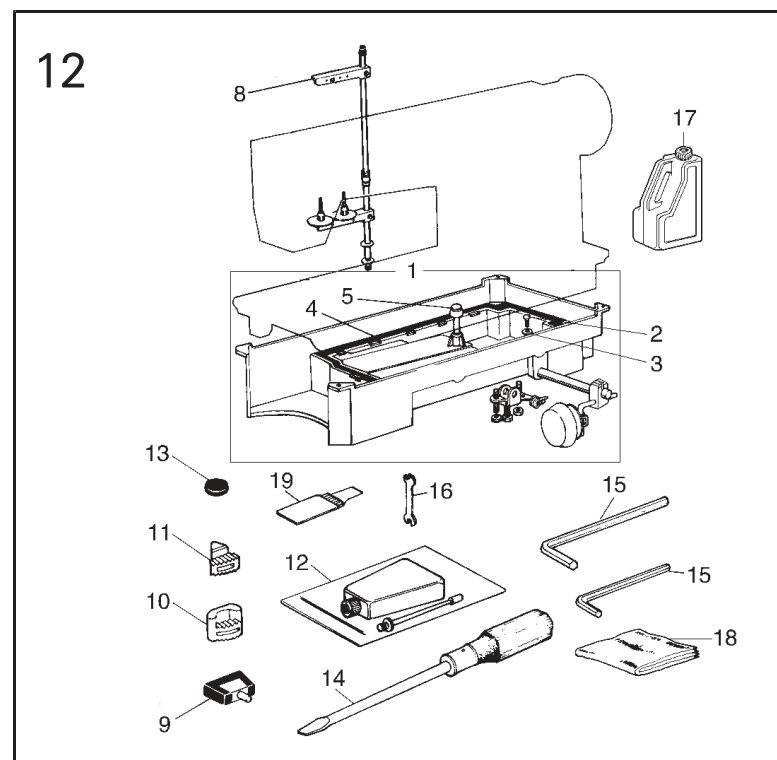

XI'AN TYPICAL INDUSTRIES CO.,LTD.

Add: No.335 Taibai South Road,  
Xi'an,P.R.China-710068  
Tel :+86-29-88279091 88279150  
Fax :+86-29-88249715 88245215  
E-mail:typical@chinatypical.com  
Http:www.chinatypical.com  
Http:www.globalsources.com